

MC30XB | PWM Bluetooth IP68 Waterproof LED intelligent grouping controller

MC30XB Series controllers+MESH Series remote control Specification

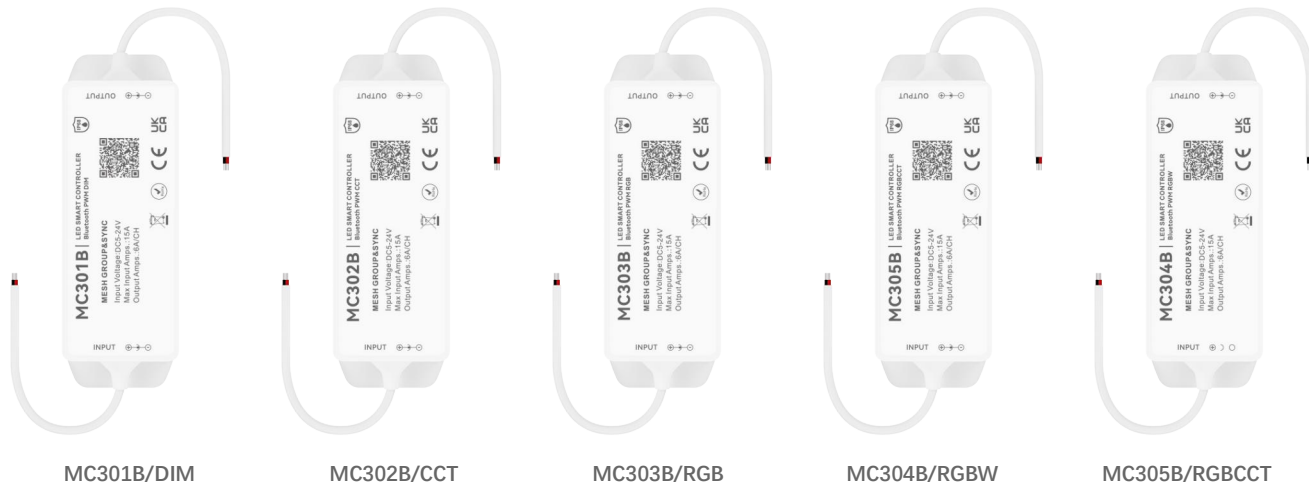

Compatible remote controls A single device can support 10 remote controls at the same time



Compatible voice assistants

Support language command switch, brightness, color.



IP68 Waterproof MESH LED Controller is a Smart LED product with IP68 waterproof performance, which is used to control various lamps with led as light source, and its controller can support MESH signals.

The connection adopts the advantages of waterproof interface, shell laser marking is not easy to fall, flexible and fast operation, convenient wiring, etc., which can be widely used in outdoor, decoration scene lighting and other places

peculiarity

- MESH wireless transmission technology, stable signal and strong penetration.
- Support matching multiple devices, multiple devices can be controlled at the same time, and one remote control can manage and synchronize up to 500 controllers. Each controller can be supported by 10 remote controls. (Control distance 30 meters)
- The brightness of the remote control can be adjusted according to personal preference, and the brightness and speed of the dynamic mode can be edited.
- The controller can adjust the brightness, color, voice control, select various dynamic or custom scenario modes, timing, countdown and other functions through the Tuya/Smart Life APP.
- Device click to run and automate, automatic transfer and synchronization function.
- PWM (Pulse Width Modulation) technology is adopted to ensure smooth light transition and avoid eye fatigue.
- Voice control, support Asia Alexa, Google Assistant, Tmall Genie, Xiaomi Xiaoai voice assistant and other speakers.
- Support multi-controller cascade, easily cover large-area lighting scenes such as shopping malls, theaters, building facades, etc.
- With IP68 protection level, it can completely prevent dust from entering, and can work normally in a long-term immersion environment, can resist heavy rain, water splash, soaking, etc., and is suitable for outdoor humid environments, underwater environments and indoor high-humidity places

Device parameters

LED controllers

Input voltage	DC 5-24V
Input current	6/CH; 15A max
Access signal	MESH+BLUETOOTH
Control the distance	30M
Size	L113XW39XH25mm
Authentication	CE,ROHS

Environment

Operating temperature	Ta: -20°C ~ +60°C
Maximum temperature of the case	Tc: +65°C
IP rating	IP68

Wrap

Package size	L13.5XW8.3XH5.5cm/0.1756kg
Box size (100 pcs)	L42XW29XH30cm/6kg

LED remote control

voltage	3V(AAA+2PCS)
Operating current	10mW
Transmission frequency	MESH (2.4GHz)
Transmit power	6dBm
Color temperature range	2700K-6500K
Dimming range	1-100% Infinitely dimming
Remote control distance	30M
Size	L122XW53XH21mm
Operating temperature	Ta: -20°C ~ +60°C
Authentication	CE,ROHS

Wrap

Package size	L13XW5.8XH2.7cm/0.105kg
Box size (100 pcs)	L27XW30XH15cm/11kg

Equipment mechanism and installation

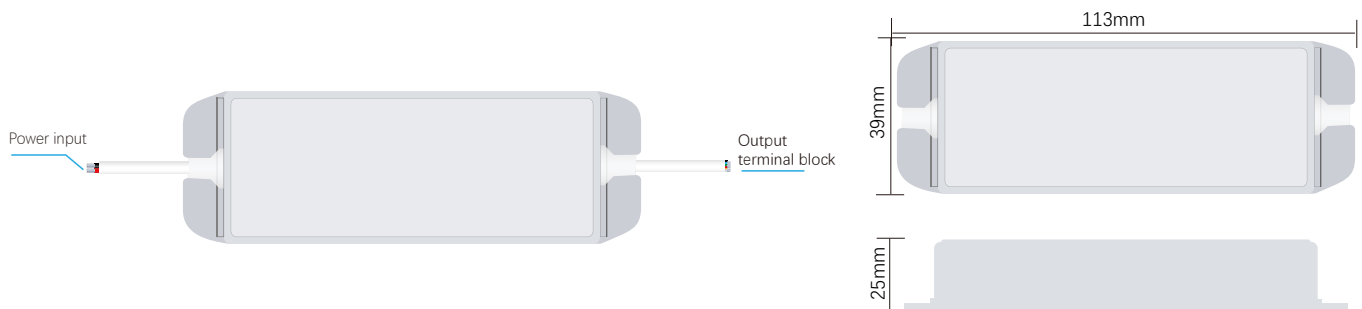

Wiring diagram of the device

Connect the strip light

AC100-240V

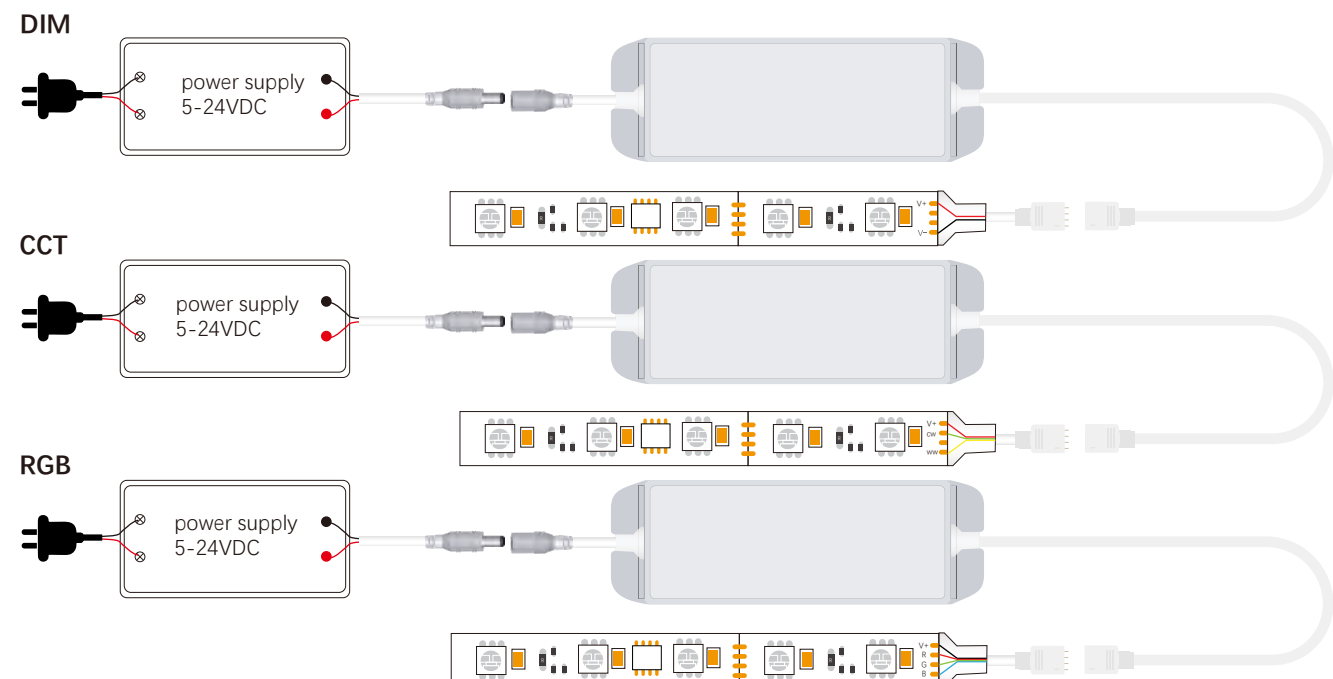

RGBW

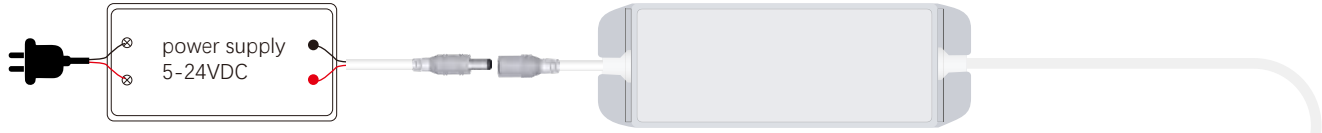

RGBWC

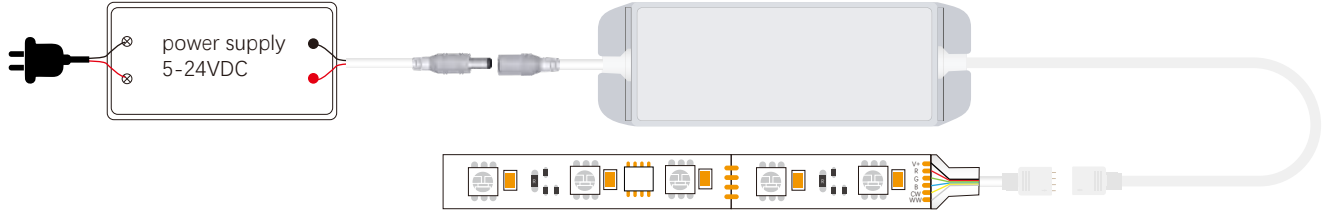

Schematic diagram of the control connection

MESH wireless communication technology

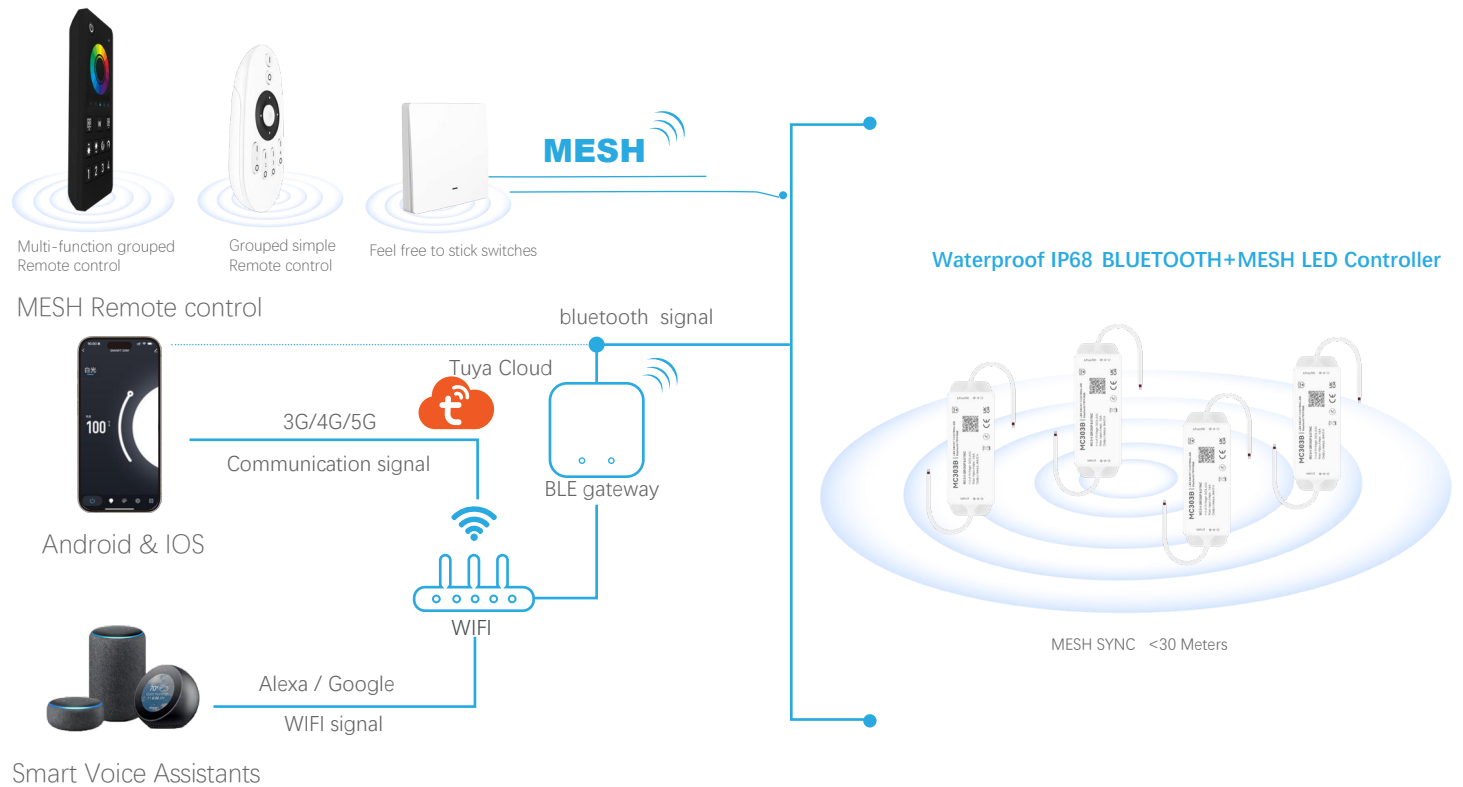

Tuya smart download & APP network connection

1. Download and install the [Smart Life] or [Tuya Smart] APP

Search for [Tuya Smart] on Apple or Google Play or scan the QR code below to download and install the app.

Please click on the "Sign Up" button to create an account and use it for the first time, if you already have an account, log in directly.

Please download the corresponding Tuya/Smart Life APP according to your region.



Scan the QR code to download the APP







Smart Life APP



Tuya Smart APP

2. Product function description & reset the device

function		Power-off mode
 SET key	ON/OFF	NVA
 MESH Remote Control	The remote control is paired	3 Times
 Android & IOS	WiFi Connect	5 Times
	Clean up and reset	10 Times



3. Connect to your smartphone

1. Make sure your smartphone is working under a WLAN network.
2. Open the login application, power off and power on five times to add the device. If you do not find the required device, please click the "+" button in the upper right corner, then manually select "Add Device" and wait for the connection to complete.
3. Once the connection is successful, the new device will be displayed on the home page, then tap on the device and enter the control interface to do more

Follow these steps to complete the connection:

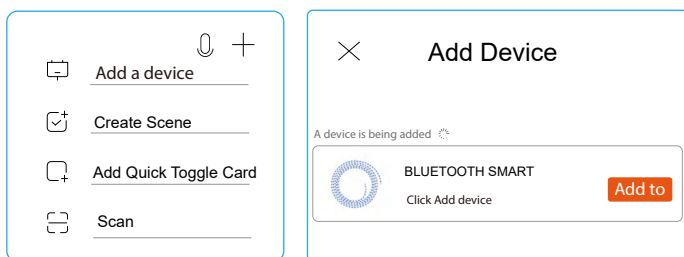

Tuya APP interface

Main interface: white light mode; color temperature mode; IPL mode; Color light mode+ White light mode; Color light mode+ color temperature mode;

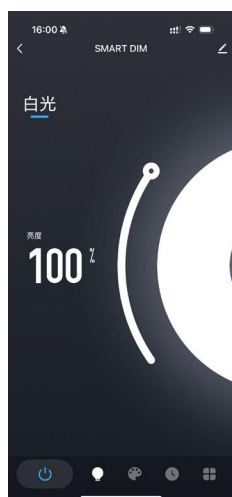

white light mode
DIM

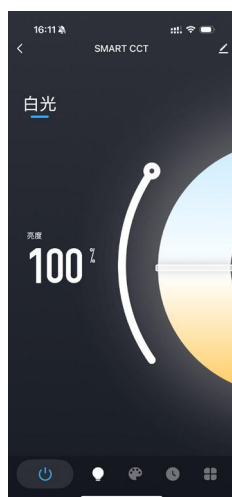

color temperature mode
CCT



IPL mode
RGB

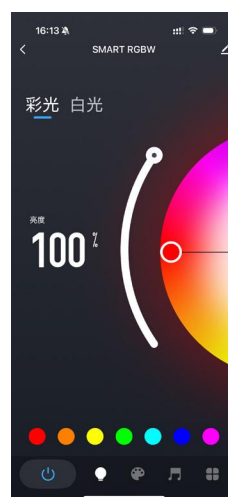

Color light mode+
White light mode
RGBW



Color light mode+
color temperature mode;
RGB CCT

MC301B、MC302B Tuya app interface

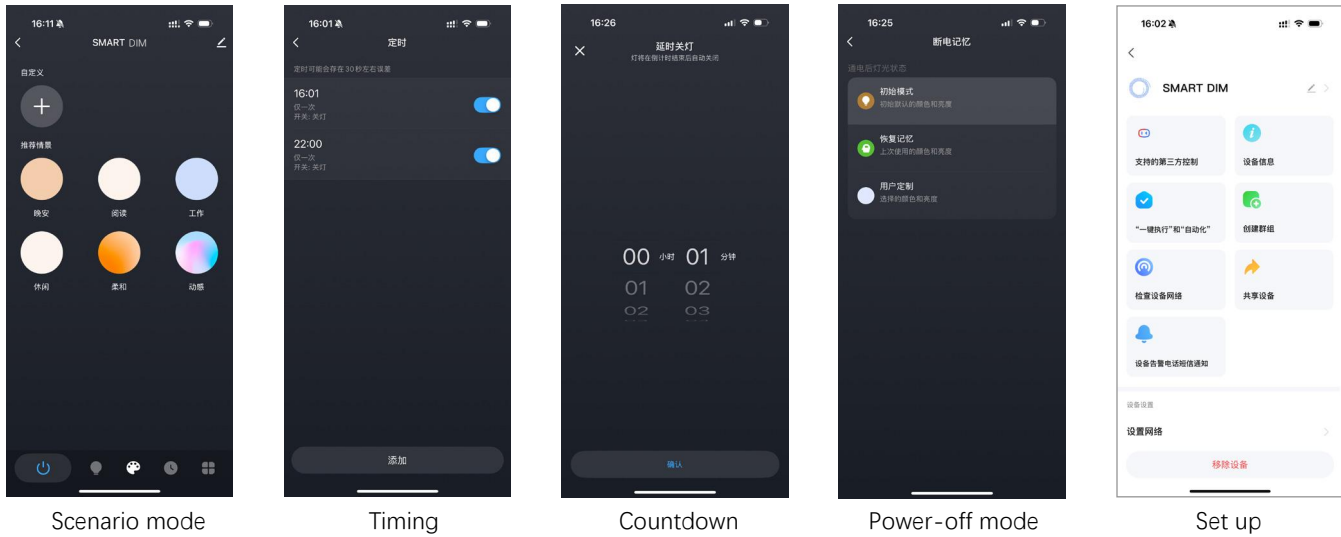

White light mode/color temperature mode: one-key switch, basic dimming

Custom Scenes: Six Scenario Modes Customize the static, jumping, breathing, color, brightness, and transformation speed of the scene, a total of 4 scenes can be customized.

Timing: Customize multiple times to perform on/off light actions. There may be an error of about 30 seconds in timing.

Countdown: Customize the countdown time to perform the on/off action of the lights, and the lights will automatically turn off after the countdown ends.

Power-off memory: Power-on reaction can set the state of the light after power-on.

Settings: This interface can be bound with third-party language control, one-click execution and automation, group creation, device sharing and other functions

MC303B、MC304B、MC305B Tuya app interface

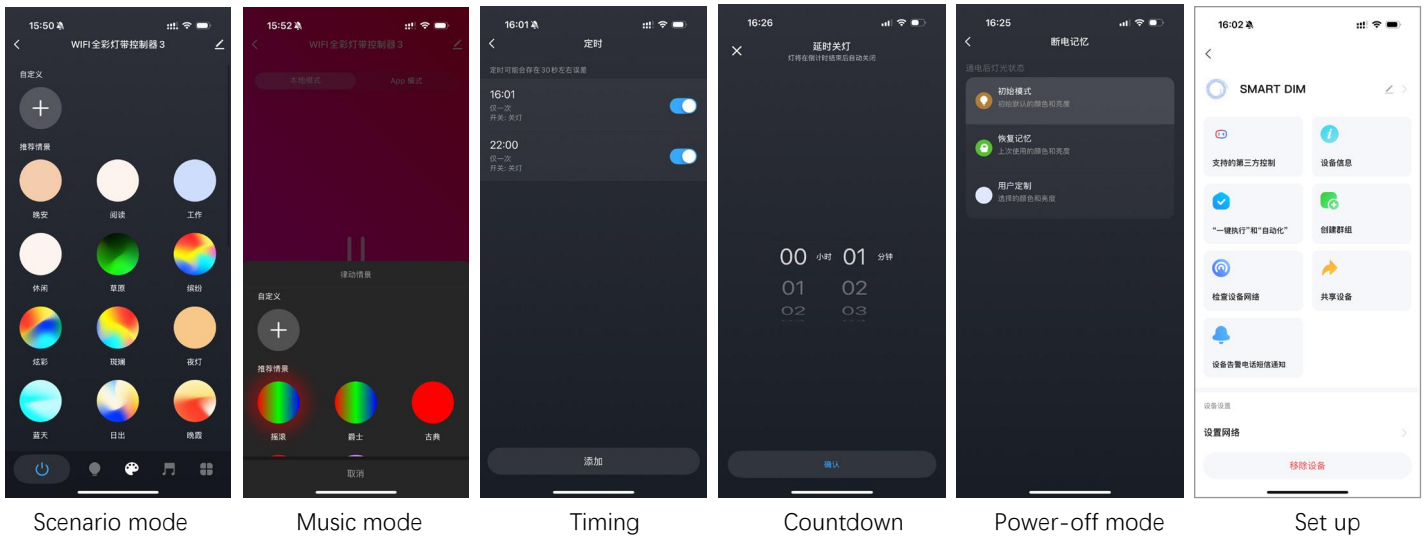

IPL mode/IPL&White mode/IPL&color temperature mode: one-key switch, IPL: set the color and brightness of the light, one-key shortcut color. White Light: Set the brightness and color temperature of white light.

Custom scenes: 32 story modes (30 story modes in RGB) Custom custom can adjust the static, jumping, breathing, color brightness, and change speed of the scene, a total of 10 scenes can be customized.

Music Mode: Local Mode: Adjustable Sensitivity, 5 Recommended Scenes, Custom Rhythm Scenes, a total of 3 Custom Rhythm Scenes can be added. APP mode: the sensitivity is not adjustable, you need to turn on the mobile phone microphone to detect the music.

Timing: Customize multiple times to perform on/off light actions. There may be an error of about 30 seconds in timing.

Countdown: Customize the countdown time to perform the on/off action of the lights, and the lights will automatically turn off after the countdown ends.

Power-off memory: Power-on reaction can set the state of the light after power-on.

Settings: This interface can be bound with third-party language control, one-click execution and automation, group creation, device sharing and other functions

Description of the function of the remote control

Multi-function grouped Remote control

 Main ON/OFF button
 1 2 3 4 Grouping key
 Short press; Select the key function. Long press; Perform key functions.

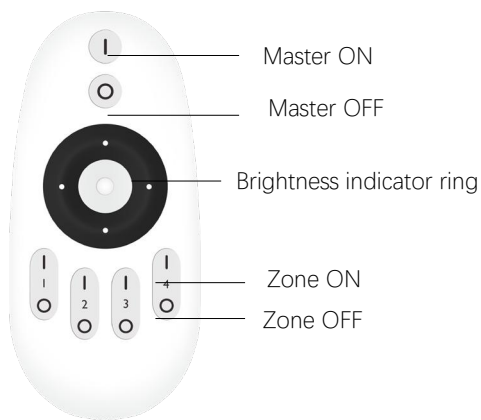

Grouped simple Remote control



Feel free to stick switches

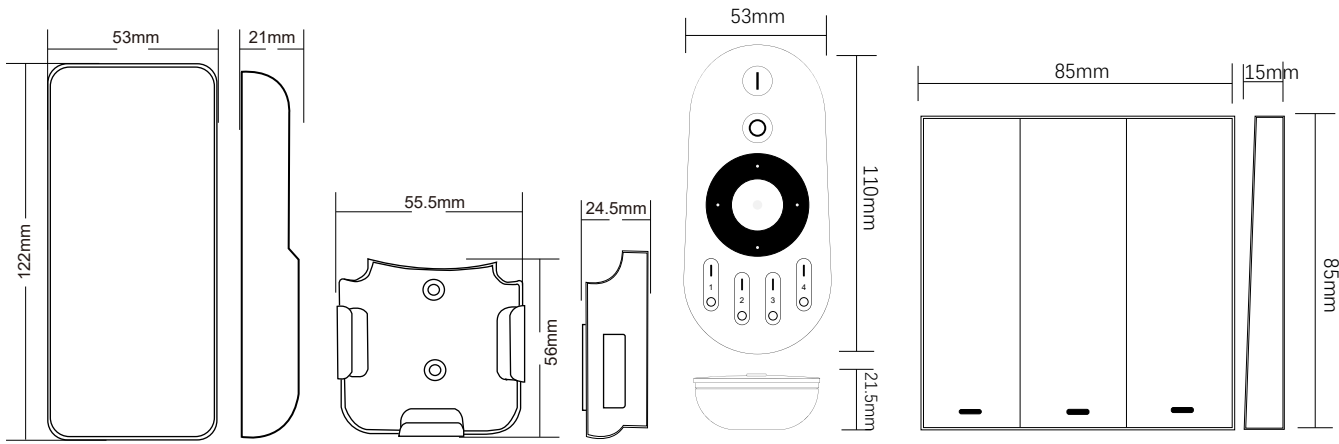

Safety Precautions

1. The remote control is a precision electronic product, please do not use it in a humid or high temperature environment for a long time. If not in use for a long time, remove the battery and store it in a cool, dry place.
2. Do not use this device in a large area of metal or in an environment with strong electromagnetic waves nearby, otherwise it will seriously affect the control distance
3. Please check whether the input voltage of the constant voltage power supply meets the requirements of the controller, and check whether the connection of the cathode and anode is correct.
4. The working voltage is DC 5~24V, if the voltage is higher than 24V, the controller will be damaged.
5. Non-professional users cannot directly disassemble the controller, otherwise it may cause fire and electric shock.
6. The working temperature (Ta) is -20~60°C; Do not use the device in direct sunlight, humidity, or other high-temperature areas.
7. When the equipment load reaches 15A, the wire diameter must be more than 1.5 square millimeters
8. When the device load exceeds 10A, the connection cable from the DC port to the LED strip must be shorter than 40cm.
9. Please install the device in a good heat dissipation area.